

WORLD CLASS · EFFICIENCY · RELIABILITY

k|r|o|f

TWO STAGE OIL FREE ROTARY



Kaishan Compressor USA



**Engineered, Designed,
Machined, Assembled
and Tested in the USA!**

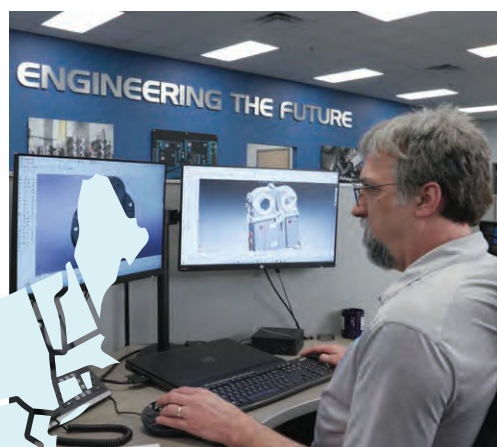

USA
HEADQUARTERS
LOCATED IN
LOXLEY, AL



KAISHAN USA'S HEADQUARTER FEATURES

- Oil Free Design Center for the entire Kaishan Group
- 60Hz Center of Excellence
- 100+ Years of Engineering Design Experience
- State of the Art Machining Centers
- Quality Focused
- Cutting-Edge, Lean Manufacturing Techniques



PRECOOLER / INTERCOOLER

- Precooler reduces thermal stress load
- Highly efficient robust 2 stage cooling
- Approach temperatures under 15 °F degree (compared to competitors that are in 32 °F)



HYDRAULICALLY CONTROLLED INLET VALVE

- Quicker response to system changes
- Lower starting inrush current
- Control independent of operating pressure
- Reliable, robust design



UNIQUE PACKAGE LAYOUT

- Package is split into cold / hot side
- Cooling air efficiently distributed through packaged
- Each aspect of package designed for sound attenuation



INLET FILTER / DUCTING

- High flow / low pressure drop
- Clean fresh air
- Noise reduction
- Minimize restriction

COOLING FANS

- Aerospace grade Polycarbonate
- Dynamically balanced
- Extremely Efficient
- Modular designed integrated motor
- High static pressure capability

CONTROLS

- Critical operating parameters monitored and controlled for safe operation
- Networking capable of 16 machines
- Multi-lingual capabilities
- Rugged and robust – UV protected
- Alarms and maintenance reminders

SERVICABILITY

- Minimal service parts
- Minimal service time
- All PMs parts on same corner
- Spin on oil filter

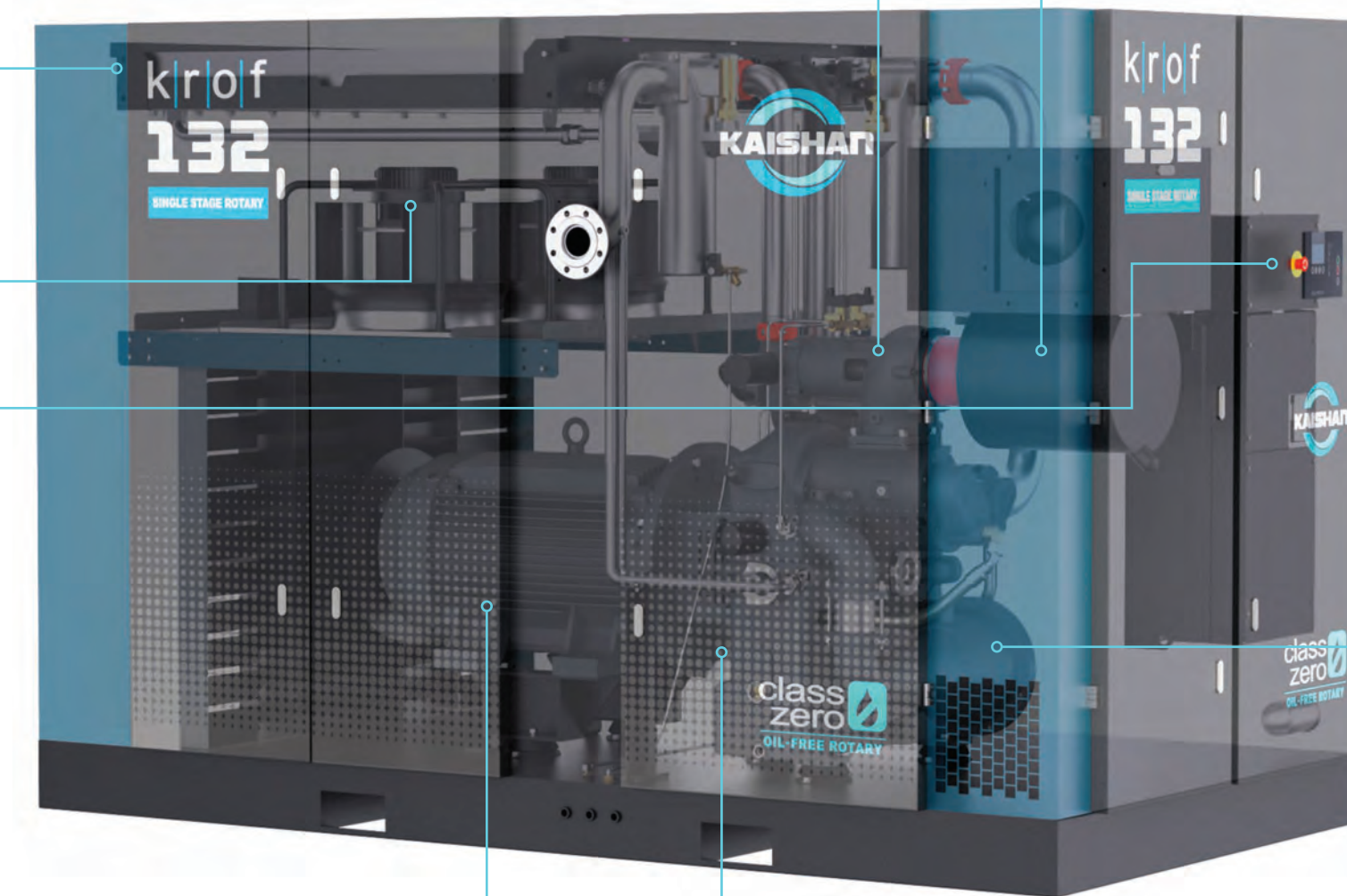

MOTOR

- IEC TEFC IE3 Premium Efficiency – IP55 protects against dust, chemicals and humidity
- Flexible Direct coupled
- Integral motor adapter for guaranteed alignment

OIL FREE AIREND

- Integrated oil distribution lines
- Integrated motor adapter
- Proprietary rotor profile
- PTFE coating on compression chambers
- Seal design ensures zero oil in compressed air

- Pressure versatility
- Integrated oil pump



INTEGRATED PULSATION DAMPENERS

- Industry leading low dBA
- Reduces pressure spikes
- Laminar flow

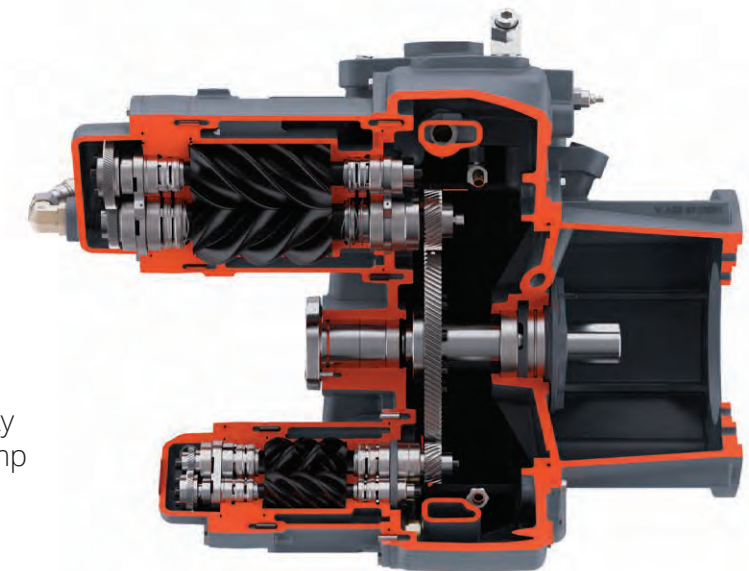

WHAT IS RIDING ON YOUR AIR QUALITY?

The presence of oil in a compressed air system can lead to product defects, spoilage, and even recalls. With a Kaishan Oil Free rotary you have the peace of mind that only the highest purity of compressed air is reaching your products.



Food and Beverage



Pharmaceutical



Chemical

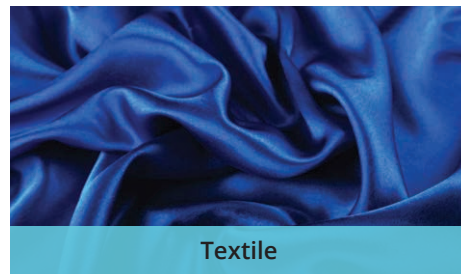

Textile



Utilities

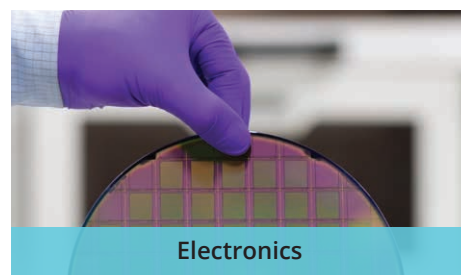

Electronics



AIR QUALITY STANDARDS ISO 8573.1

CLASS	Concentration total oil (aerosol, liquid, vapor) mg/m ³
0	As specified by the equipment user or supplier and more stringent than class 1
1	< 0.01
2	< 0.1
3	< 1
4	< 5

50 HZ DATA - TECHNICAL DATA

MODEL	POWER kW	FLOW (CFM / M3/min)				SOUND dBA	WEIGHT		DIMENSIONS (LxWxH)		Connection Size
		105 psi	8 bar	150 psi	10 bar		lbs	kg	in	mm	
KROF-22	22	In Development									
KROF-30	30										
KROF-37	37										
KROF-45	45										
KROF-55	55										
KROF-75	75										
KROF-90	90	569	16.11	523	14.81	84	9860	4472	136x76x89	3452x1930x2260	DN 80
KROF-110	110	690	19.54	641	18.14	84	9940	4509	136x76x89	3452x1930x2260	DN 80
KROF-132	132	822	23.28	759	21.5	84	10105	4584	136x76x89	3452x1930x2260	DN 80
KROF-160	160	954	27.01	911	25.79	84	10220	4636	136x76x89	3452x1930x2260	DN 80
KROF-190	190	In Development									
KROF-225	225										
KROF-260	260										
KROF-315	315										

READY TO TAKE THE EFFICIENCY TO THE NEXT LEVEL?

KROF VSD combines a robust power platform with a state-of-the-art control scheme

The drive provides a soft start and the ability to operate efficiently through the compressor's capacity range by matching flow to demand, while maintaining a high level of pressure control. By eliminating wasted energy, cost savings as high as 35% or more are possible. With this level of savings, the additional capital cost of the variable speed drive can be recovered in less than one year's operation.

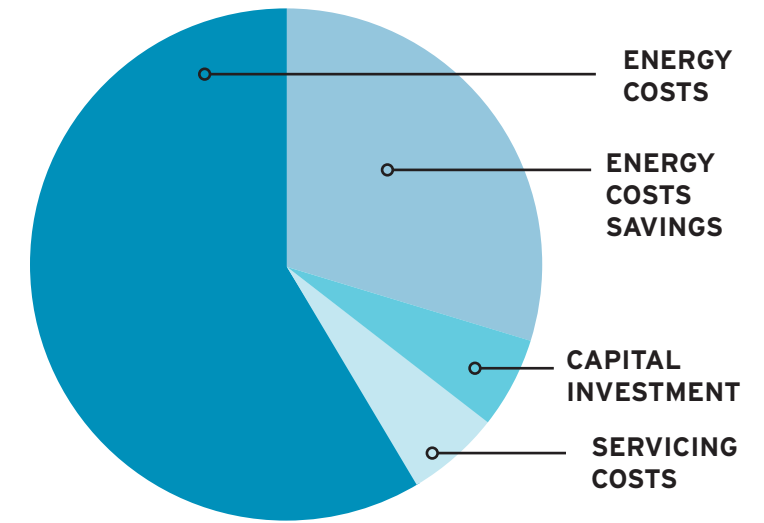

KROF Series VSD Rotary Screw Compressor operating at 70% load compared to a fixed speed model.

TOTAL INTEGRATED SYSTEM CONTROL

KROF controller capabilities include the following:

- Operating parameters
- Maintenance schedules
- Warning stop alarms
- Compressor history

The control panel contains a special programmed microprocessor that can safely and efficiently control all functions of the compressor.



The controller monitors line pressure, oil temperature and working conditions (running, idling and stop). Abnormal conditions will trigger a flashing LED and a message indicating the cause for the alarm.

60 HZ DATA - TECHNICAL DATA

MODEL	POWER HP	FLOW (CFM / M3/min)				SOUND dBA	WEIGHT		DIMENSIONS (LxWxH)		Connection Size
		100 psi	7 bar	125 psi	8.6 bar		lbs	kg	in	mm	
KROF-30	30	In Development									
KROF-40	40										
KROF-50	50										
KROF-60	60	341	9.65	299	8.47	84	7660	472	121x73x87	3452x1930x2260	ANSI 3" 150#
KROF-75	75	405	11.46	356	10.08	84	7780	472	121x73x87	3452x1930x2260	ANSI 3" 150#
KROF-100	100	535	15.15	470	13.30	84	7840	472	121x73x87	3452x1930x2260	ANSI 3" 150#
KROF-125	125	561	15.88	554	15.68	84	9860	4472	136x76x89	3452x1930x2260	ANSI 3" 150#
KROF-150	150	689	19.5	681	19.28	84	9940	4509	136x76x89	3452x1930x2260	ANSI 3" 150#
KROF-200	200	898	25.43	892	25.26	84	10220	4636	136x76x89	3452x1930x2260	ANSI 3" 150#
KROF-250	250	In Development									
KROF-300	300										
KROF-350	350										
KROF-400	400										



info@KaishanUSA.com

15445 Industrial Park Dr. · Loxley, AL 36511 USA

251.202.0577

KaishanUSA.com